



DIMENSIONAL DATA

501s

A	Max. height	3475 mm
B	Height to bucket swivel-joint	2700 mm
C	Cabin height	1930 mm
D	Ground clearance	225 mm
E	Tail projection (from rear axle)	898 mm
F	Wheelbase	885 mm
G	Total length without attachments	2263 mm
H	Total length with standard bucket	2860 mm
I	Max. vehicle length	3258 mm
K	Bucket height	2522 mm
L	Max. dumping height	2122 mm
M	Reach	424 mm
N	Max. reach (with horizontal arm position)	1136 mm
O	Tipping angle on the ground	30 °
P	Tipping angle	40 °
Q	Tipping angle	105 °
R	Gradient	29 °
S	Vehicle width (with standard tyres 27 x 8,5 - 15)	1230 mm
T	Bucket width	1270mm/1370 mm
U	Turn radius – tail	1381 mm
V	Turn radius – front	1656 mm

Mighty, small

Powerful skid steer loader with four maintenance-free Quattrostatic® drive travel motors. Even this basic model is fully-equipped - compact dimensions, incredibly flexible and an extraordinarily powerful performer. And Quattrostatic® drive adds greater ground clearance and maneuverability.

The 501 Skid Steer Loader is in a class of it's own, with ample power, a ROPS/FOPS - approved safety cabin as a standard feature and components specially designed to be low maintenance. It's additional ground clearance gives you more room to manoeuvre.

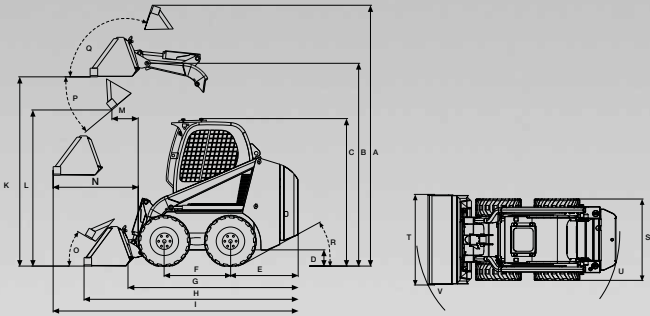

Machine illustrated may show optional features and accessories available at additional cost.

OPERATIONAL DATA

501s

Operational weight*	1810 kg
Working load	510 kg
Tipping load	1020 kg
Bucket content levelled	0,21 m ³
Bucket content heaped	0,26 m ³
Engine Make/type	YANMAR 3TNV88
Model	water cooled, 3-cylinder diesel engine
Net engine output	27 kW (36 Hp)
Capacity	1642 cm ³
Operating speed	3000 min ⁻¹
Battery	12 V, 71 Ah
Diesel tank volumes	45 l
Hydraulic System Pumps	gear pumps
Work hydraulics operational pressure	185 bar
Work hydraulics hydraulic output	42 l/min
Hydraulic oil cooler	combi-cooler, standard feature
Hydraulic tank content	45 l
Travel Drive Pumps	Axial piston-variable displacement pump
Travel speeds	10,5 km/h
Standard tyres	8,5 - 15
Drive concept	Quattrostatic® 4 separate travel motors/gear units
Brake	hydraulic parking brake

* With standard bucket, full tanks and driver (80kg).



DIMENSIONAL DATA

701s/701sp

A	Max. height	3620 mm
B	Height to bucket swivel-joint	2860 mm
C	Cabin height	1947 mm
D	Ground clearance	252 mm
E	Tail projection (from rear axle)	1056 mm
F	Wheelbase	890 mm
G	Total length without attachments	2440 mm
H	Total length with standard bucket	3060 mm
I	Max. vehicle length	3517 mm
K	Bucket height	2660 mm
L	Max. dumping height	2325 mm
M	Reach	516 mm
N	Max. reach (with horizontal arm position)	1173 mm
O	Tipping angle on the ground	29 °
P	Tipping angle	35 °
Q	Tipping angle	105 °
R	Gradient	27 °
S	Vehicle width (with standard tyres 10 x 16,5)	1475 mm
T	Bucket width	1520 mm
U	Turn radius – tail	1520 mm
V	Turn radius – front	1771 mm