

OPERATING PERFORMANCE

Operating Weight - Cab	5,085 kg
Operating Weight - Canopy	4,970 kg
Bucket Capacity (Heaped)	0.141 m ³
Slew Speed	8.9 min ⁻¹
Travel Speed	
1st	2.8 km/h
2nd	5.0 km/h
Gradeability	30°
Ground Pressure - Cab	28.9 kPa
Ground Pressure - Canopy	28.2 kPa
Maximum Bucket Breakout Force	37.3 kN
Maximum Arm Digging Force (1,400 mm Arm)	25.0kN
Maximum Arm Digging Force (1,650 mm Arm)	22.4 kN
Traction Force	54.8 kN
Boom Swing Angle (Left/Right)	71° / 55°

ENGINE

Model	Kubota / V2607
Rated Output (ISO 14396)	32.4 kW / 2,000 min ⁻¹
Maximum Torque	180.1 Nm / 1,500 min ⁻¹
Displacement	2,615 ml
Alternator	12V - 0.84 kW
Battery (IEC 60095-1)	12V - 72 A·h

FLUID CAPACITY

Engine Lubrication	11.8 L
Cooling System	10.0 L
Fuel Tank Capacity	55.3 L
Hydraulic Reservoir Capacity	40.8L
Hydraulic System Capacity	85 L

HYDRAULIC SYSTEM

P1, P2	Variable Displacement Pump
Flow Rate	52.6 L/min
Relief Pressure	24.0 MPa
P3	Gear Pump
Flow Rate	40.6 L/min
Relief Pressure	20.6 MPa
Service Port 1	
Flow Rate	93.2 L/min
Hydraulic Pressure	20.6 MPa
Service Port 2	
Flow Rate	40.6 L/min
Hydraulic Pressure	20.6 MPa
Service Port 3	
Hydraulic Pressure	20.6 MPa
Service Port 4	
Flow Rate	40.6 L/min
Hydraulic Pressure	20.6 MPa

SAFETY and HEALTH

Vibration Levels	
Hand / Arm	≤ 2.5 m/s ²
Body	≤ 0.5 m/s ²
Noise Level	
Sound Power Level	L _{WA} 97 dB



Up to 4 Service Ports (Optional)



Great Stability



All Steel Construction



TFM

TB350R Compact Excavator

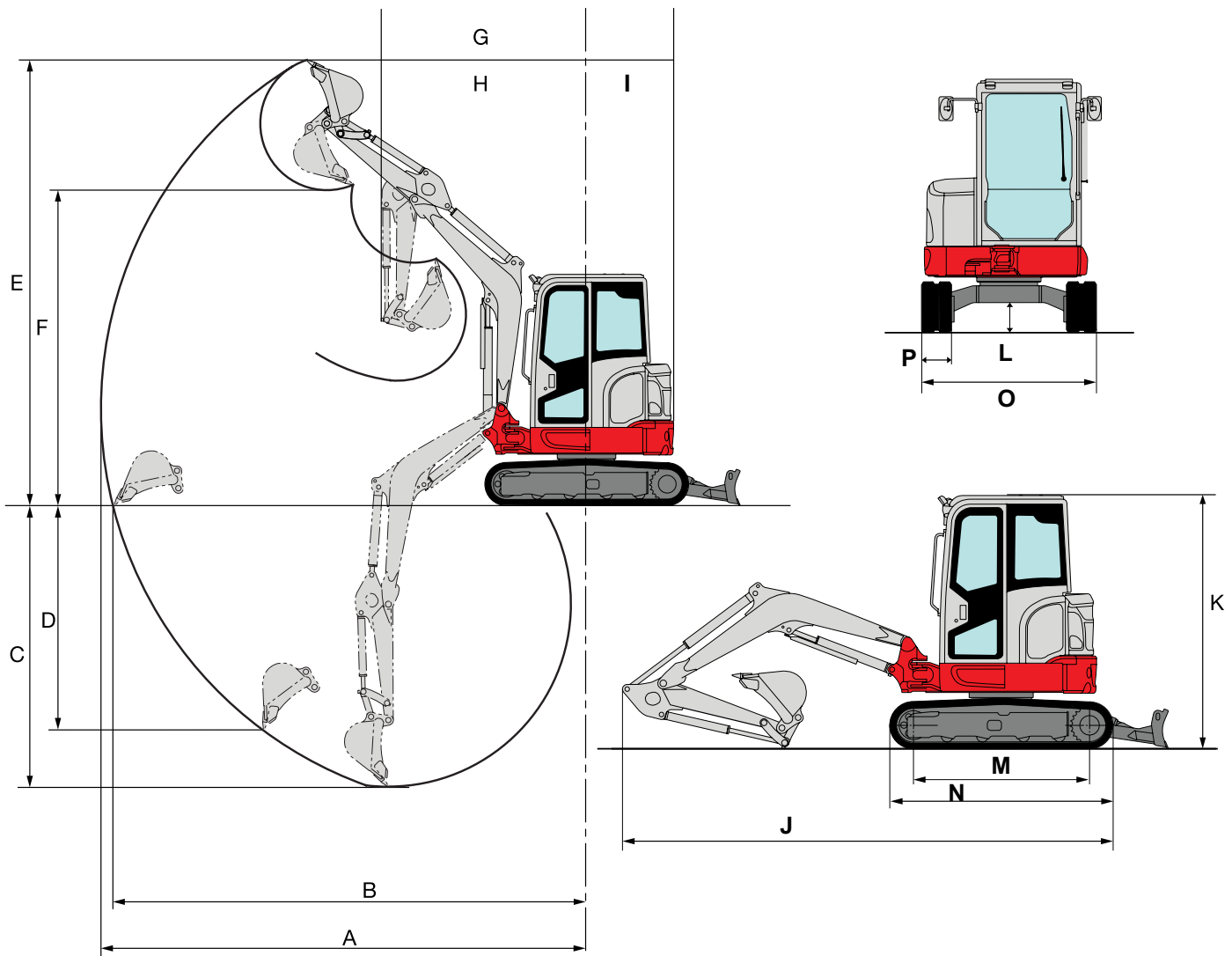

MACHINE DIMENSIONS	1,400 mm Arm	1,650 mm Arm
A Maximum Reach	5,825 mm	6,065 mm
B Maximum Reach at Ground Level	5,675mm	5,925 mm
C Maximum Digging Depth	3,325 mm	3,575 mm
D Maximum Vertical Digging Depth	2,685 mm	2,925 mm
E Maximum Height of Cutting Edge	5,410 mm	5,580 mm
F Maximum Dumping Height	3,775 mm	3,945 mm
G Front Swing Radius	2,480 mm	2,535 mm
H Front Swing Radius with Boom Offset	2,020 mm	2,065 mm
I Slew Radius	1,075 mm	
J Overall Length	5,365 mm	5,390 mm
K Overall Height (Cab / Canopy)	2,540 mm / 2,565 mm	
L Upper Structure Overall Width (Cab / Canopy)	1,775 mm / 1,735 mm	
M Ground Clearance	335 mm	
N Crawler Base	1,975 mm	
O Crawler Overall Length	2,500 mm	
P Crawler Overall Width	2,000 mm	
Q Crawler Shoe Width	400 mm	



© 2023 Takeuchi MFG. Co., Ltd. All Rights Reserved. In accordance with our established policy of continued improvement, specifications and features are subject to change without notice. Pictures may show options other than standard equipment.

FORM: TB350R Compact Excavator Spec Sheet - Mar. 2023

TAKEUCHI[™]
From World First to World Leader